

Baseband connection overview

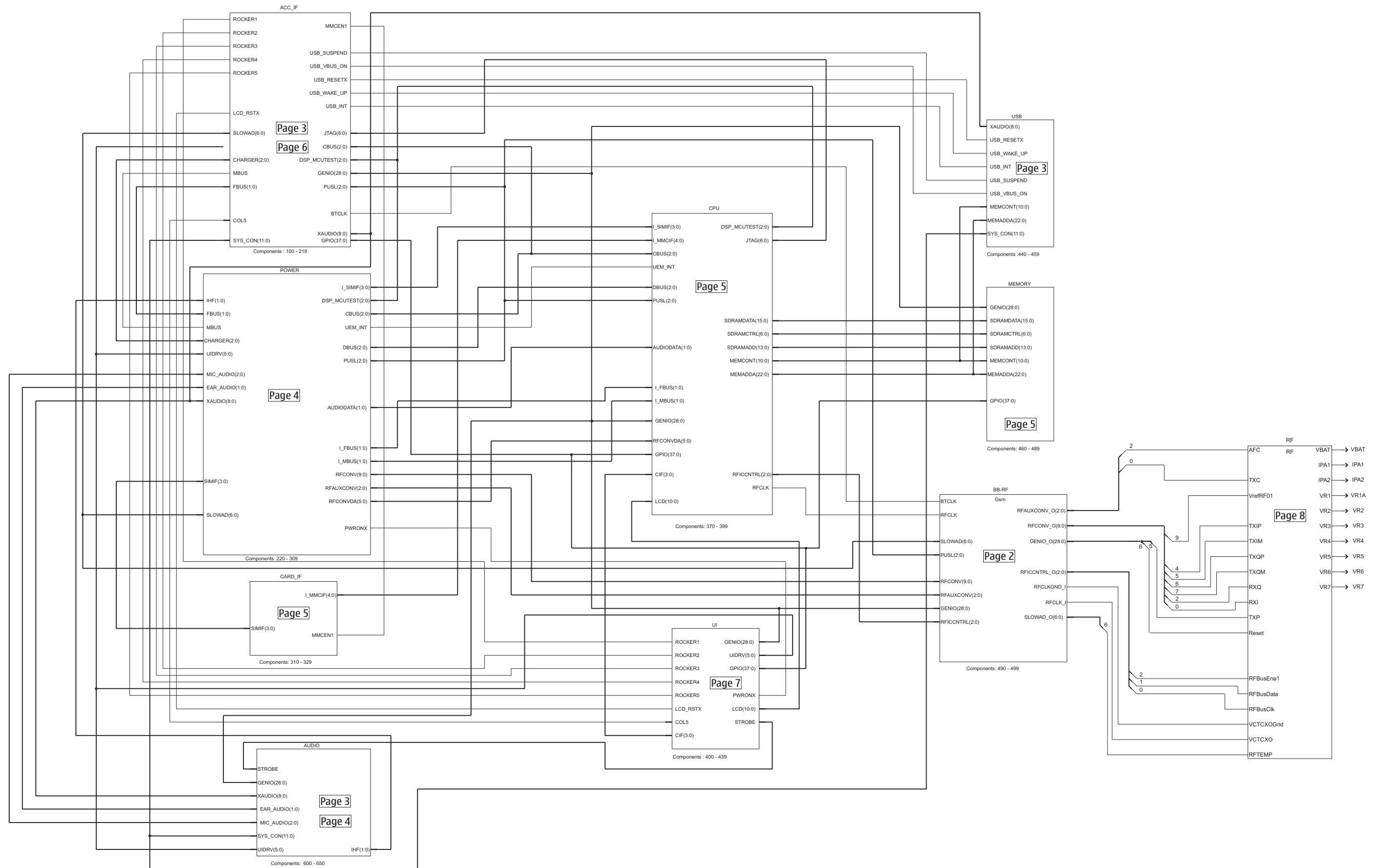

UEME, SIM, Zocus, Mic, Ear, IHF speaker

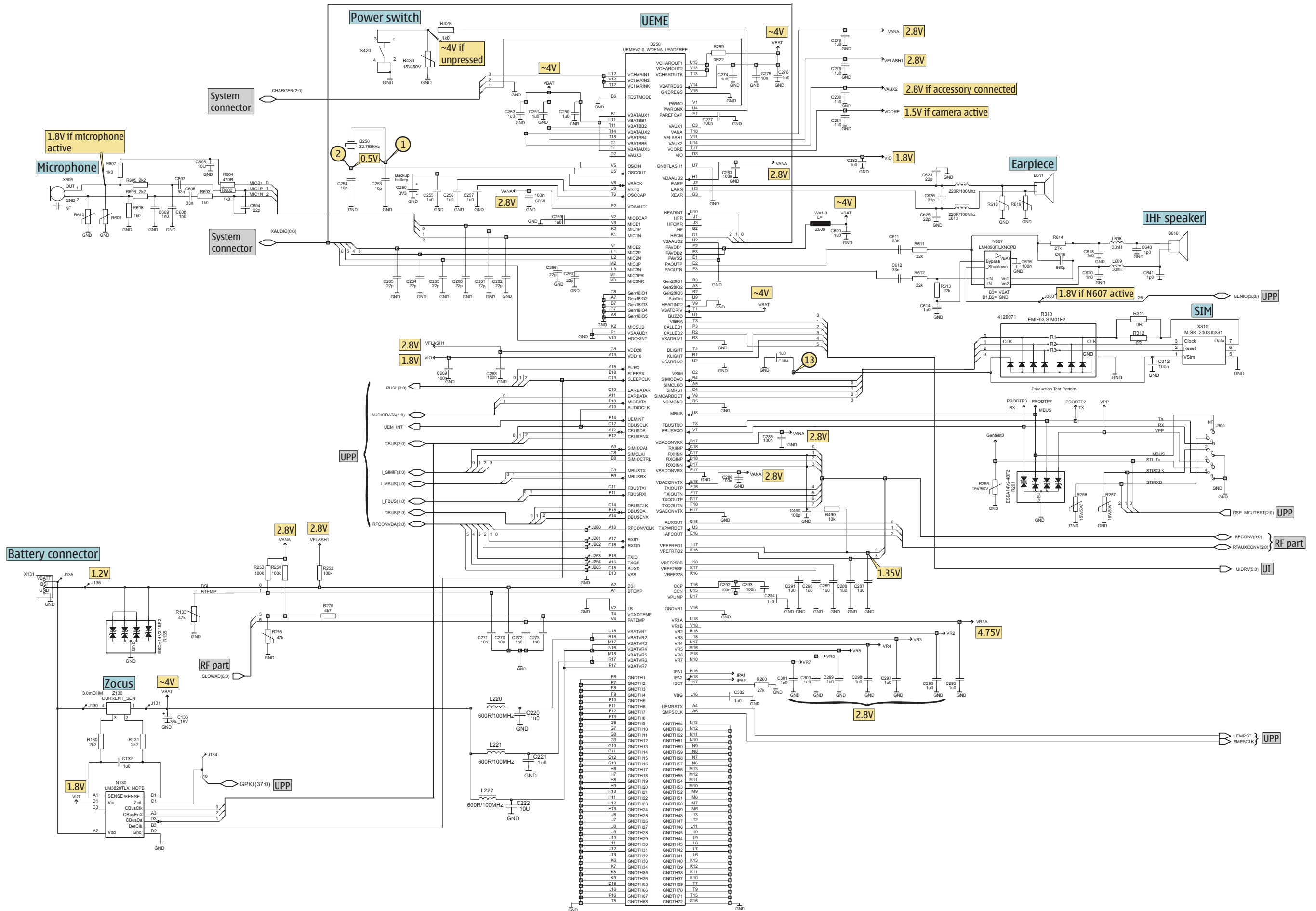

UPP, flash, MMC, camera

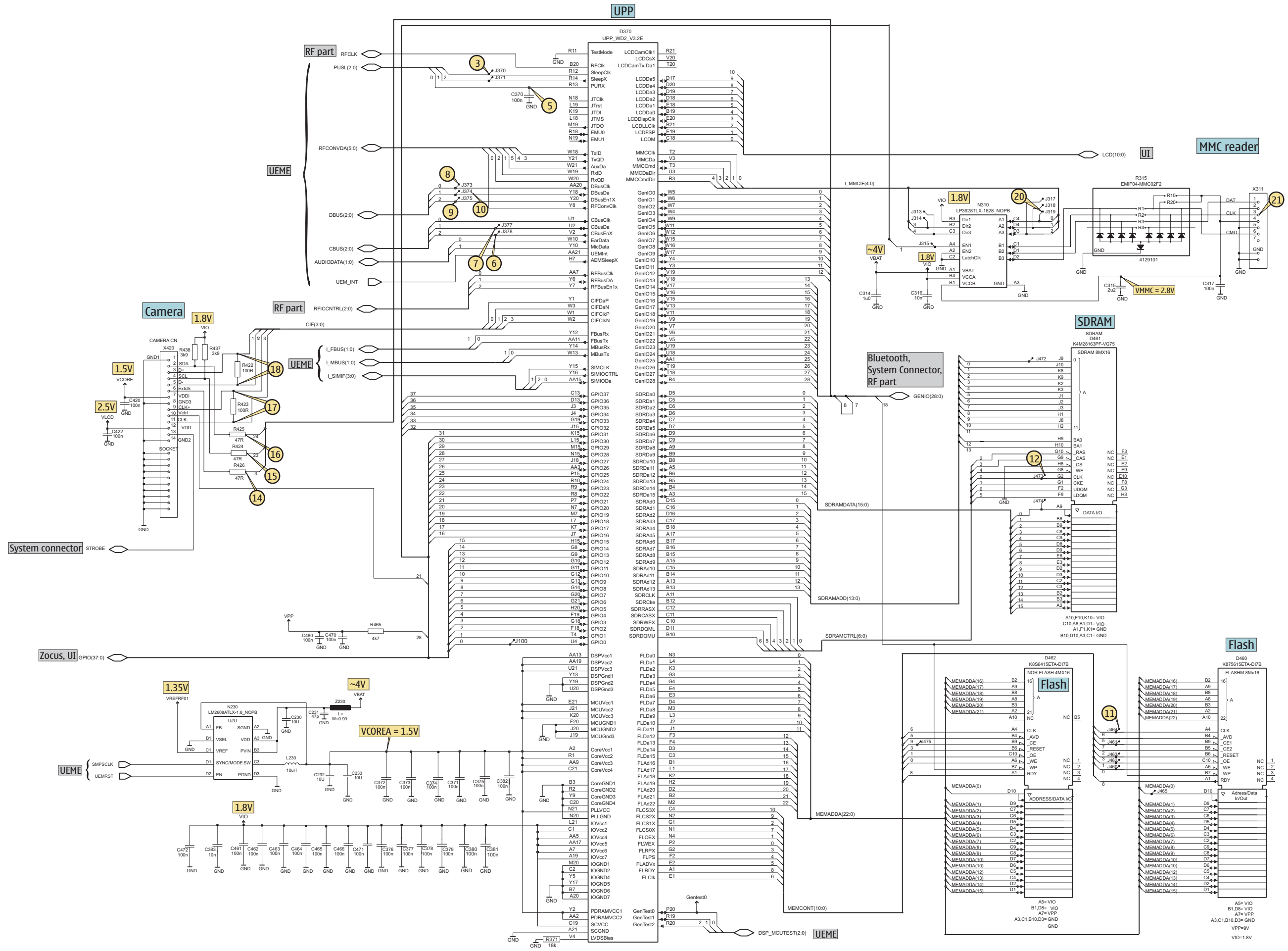

Bluetooth

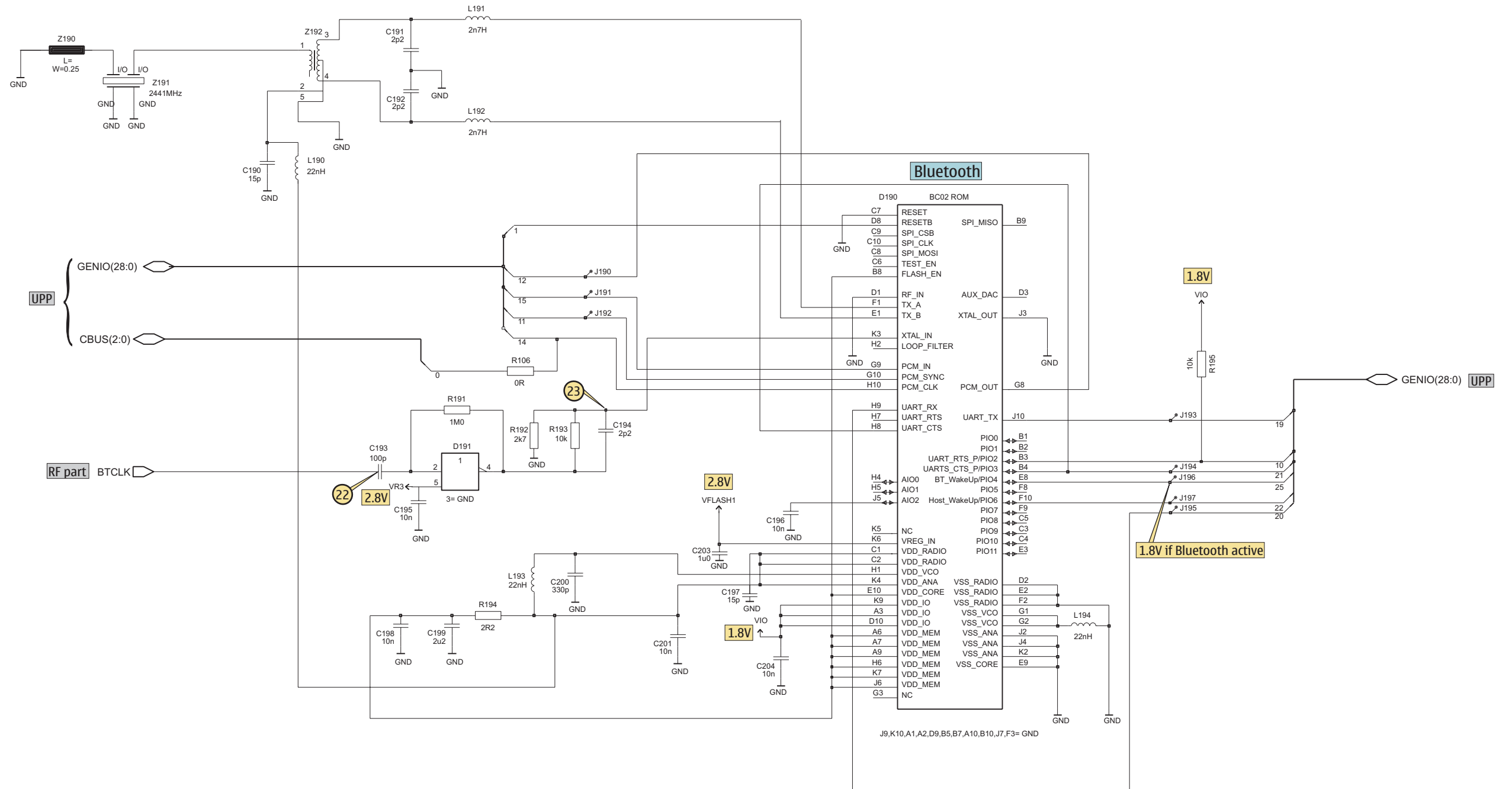

UI, vibra

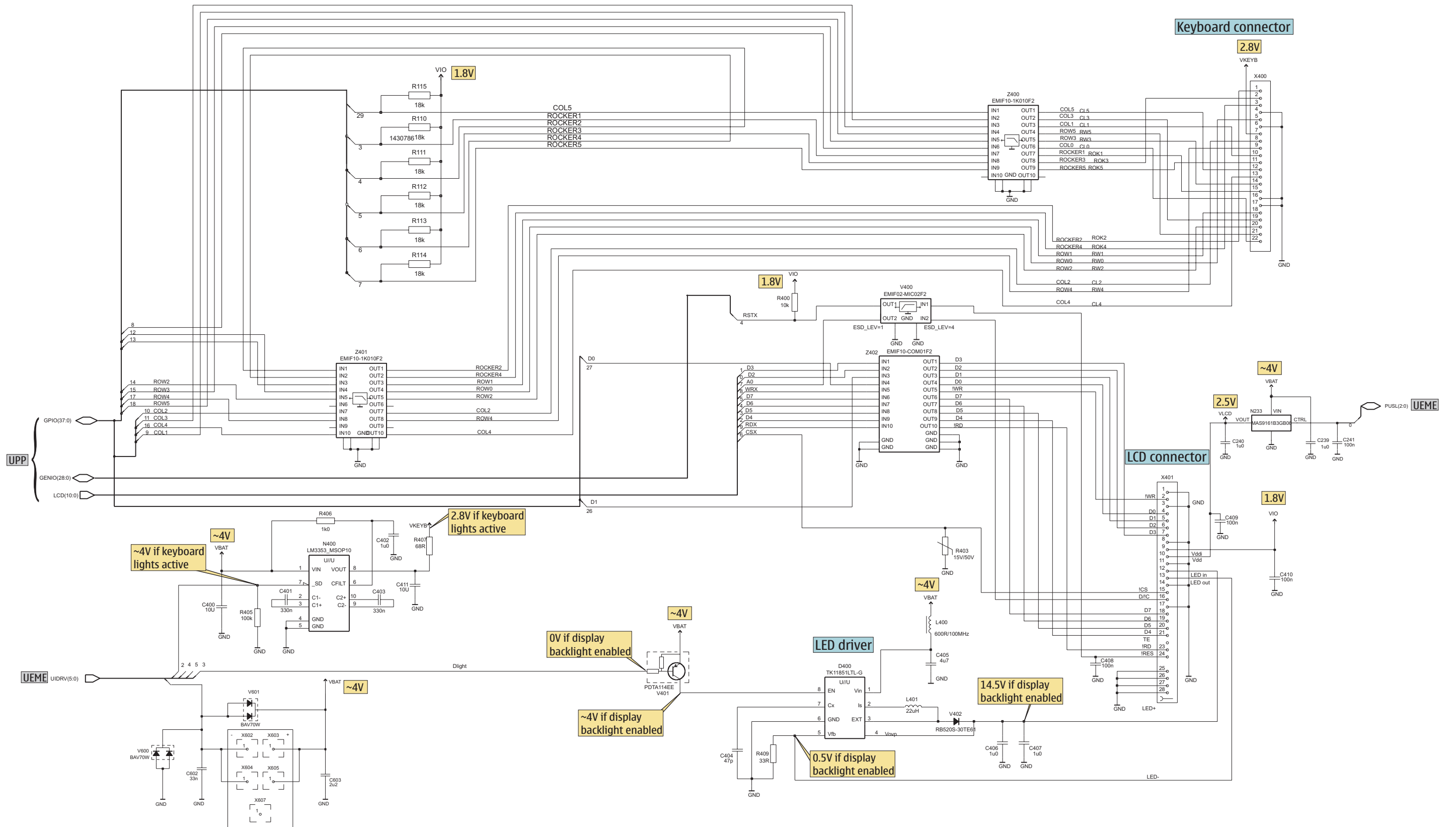

RF part

	Vc1	Vc2	Vc3
EGSM RX	-	-	-
GSM1800 RX	-	-	-
GSM1900 RX	-	2.8Vpp	-
EGSM TX	-	-	2.8Vpp
GSM1800 TX	2.8Vpp	2.8Vpp	-
GSM1900 TX	2.8Vpp	2.8Vpp	-

	RH-51 (GSM 900)	RH-52 (GSM 850)
Z700	4511443	4511445
Z803	4511455	4511449
C511	2320514	2320516

Band	Channel	RX	VCO/RX	VC/RX	TX	VCO/TX	VC/TX
EGSM 900	37	942,4MHz	3769,6MHz	~2,76V	897,4MHz	3589,6MHz	~2,03V
GSM 1800	700	1842,8MHz	3685,6MHz	~2,43V	1747,8MHz	3495,6MHz	~1,63V
GSM 1900	661	1960MHz	3920MHz	~3,34V	1880MHz	3760MHz	~2,72V

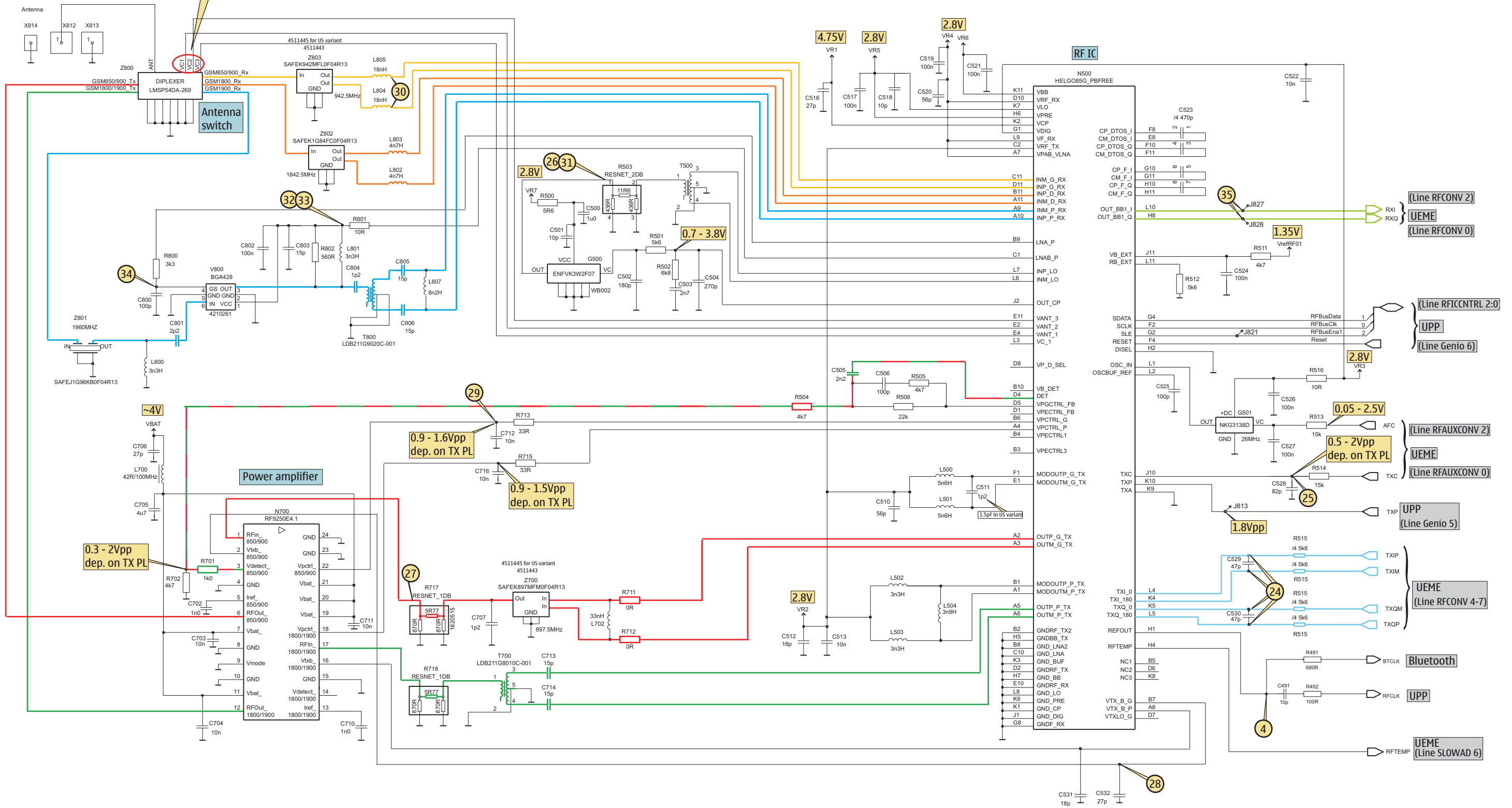

Signal overview

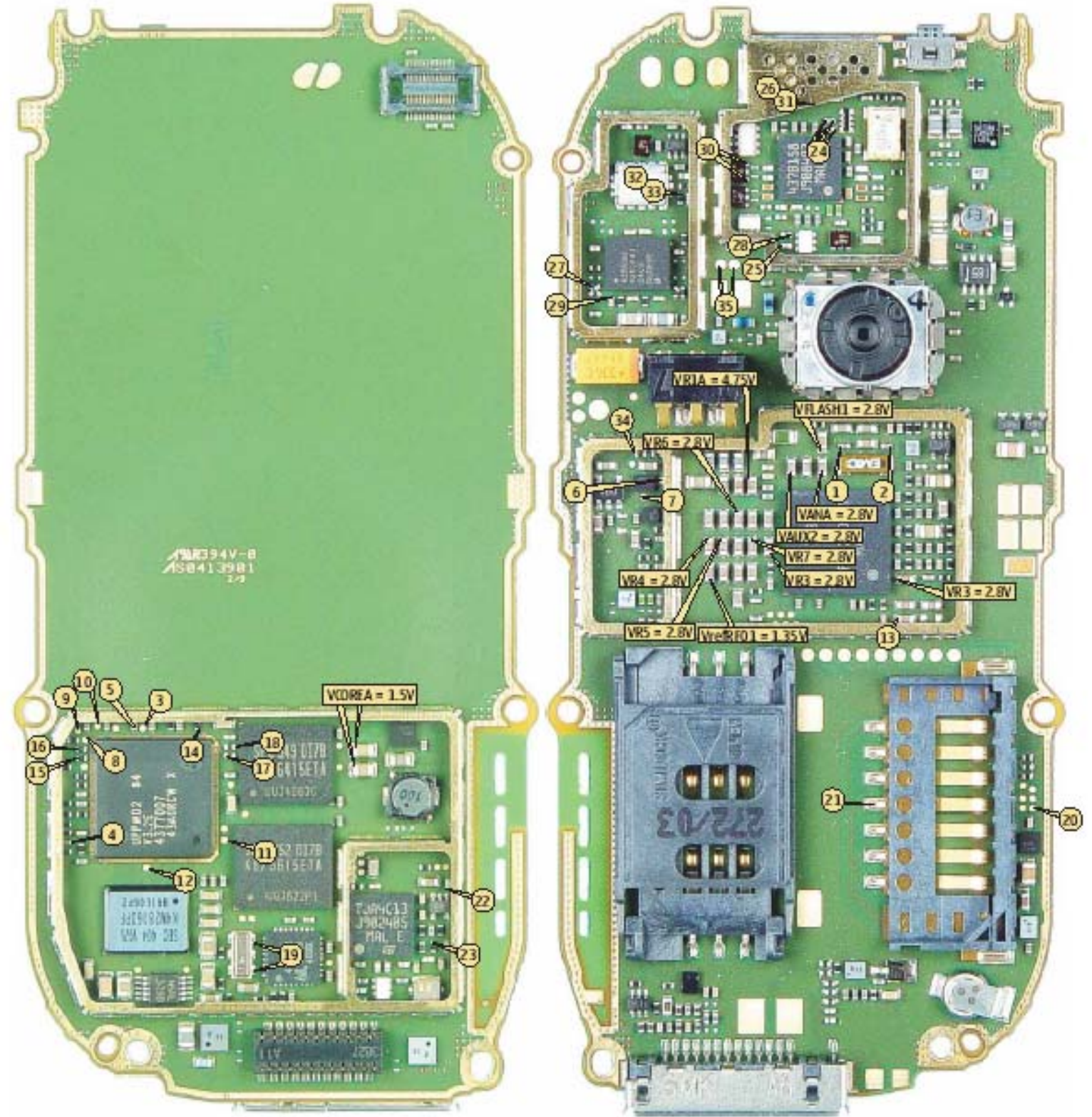
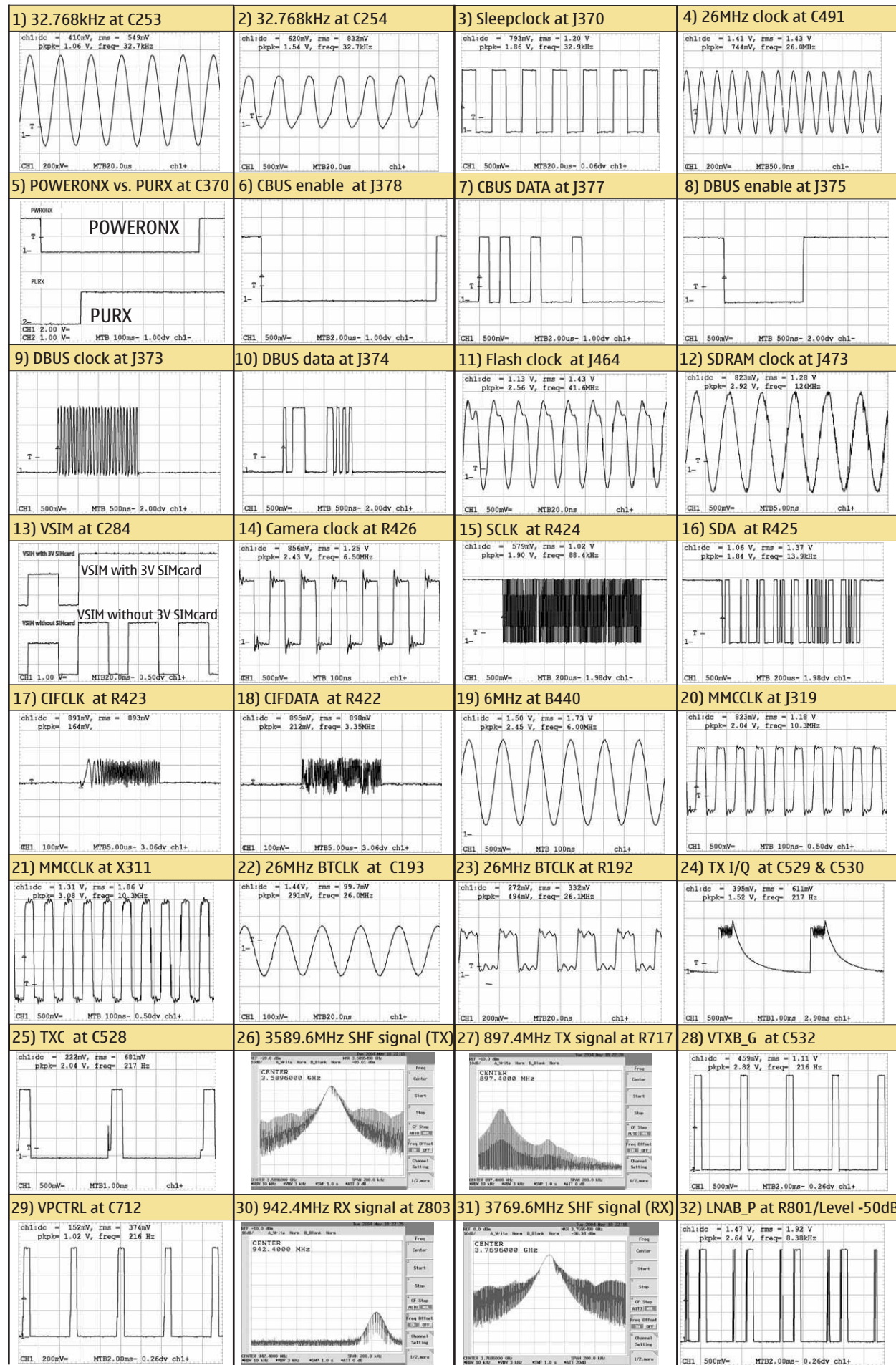

Component finder

B	C287	L5	C500	C5	C713	F7	J475	P7	R191	S3	R612	L3	
B250	J8	C288	L5	C501	C5	C714	F6	J813	P5	R192	S4	R613	L3
B440	T7	C289	L5	C502	B7	C716	G4	J821	F8	R193	S4	R614	K4
C	C290	L5	C503	C7	C800	D4	J827	F5	R194	S4	R618	C9	
C132	J3	C291	M5	C504	C7	C801	D3	J828	F5	R195	S5	R619	C9
C133	H3	C292	K6	C505	F8	C802	D4	L	R252	M8	R620	J9	
C134	T8	C293	K6	C506	F8	C803	E4	L130	U8	R253	M8	R621	J9
C135	T8	C294	K5	C510	E8	C804	E4	L131	T7	R254	J9	R622	U4
C190	T5	C295	K5	C511	E7	C805	F6	L133	T7	R255	H9	R627	T4
C191	T4	C296	K6	C512	E8	C806	E6	L190	T5	R256	P11	R628	K8
C192	T5	C297	L6	C513	E8	D	L191	T4	R257	P11	R629	K8	
C193	R3	C298	L5	C516	D7	D190	S5	L192	T5	R258	P11	R630	K8
C194	S4	C299	L5	C517	D7	D191	S3	L193	T4	R259	J6	R631	T3
C195	S3	C300	K5	C518	D6	D250	L7	L194	T4	R260	L6	R632	U4
C196	S4	C301	L5	C519	D6	D370	Q9	L220	J5	R261	J8	R633	U4
C197	T5	C302	L5	C520	E6	D400	G10	L221	J5	R270	J8	R634	U4
C198	R5	C312	M4	C521	D6	D440	T6	L222	J5	R310	M3	R635	T4
C199	R5	C314	S11	C522	D7	D460	R6	L230	Q4	R311	M3	R701	G2
C200	T4	C315	R11	C523	D5	D461	S9	L400	F10	R312	M3	R702	F4
C201	T3	C316	Q11	C524	D5	D462	P6	L401	F10	R315	S11	R711	E7
C203	R4	C317	T11	C525	D7	D614	J9	L440	U7	R371	O8	R712	E7
C204	S4	C370	O9	C526	C8	F	L441	U7	R400	E10	R713	G3	
C220	K5	C371	O10	C527	C8	F130	V8	L442	U7	R403	D10	R715	G3
C221	K5	C372	R8	C528	F6	G	L500	E8	R405	T8	R717	G2	
C222	K4	C373	P7	C529	D7	G250	T10	L501	E8	R406	T7	R718	G4
C230	P4	C374	O9	C530	D7	G500	C6	L502	E8	R407	T8	R800	D4
C231	P4	C375	Q10	C531	F6	G501	D8	L503	E8	R409	G10	R801	E4
C232	P5	C376	R7	C532	F6	J	L504	E7	R422	P7	R802	E4	
C233	P5	C377	O8	C600	M9	J100	P5	L608	H5	R423	P7	S	
C239	K2	C378	O10	C602	J11	J130	I3	L609	G6	R424	P10	S420	B9
C240	J3	C379	Q10	C603	J10	J131	I2	L612	D9	R425	P10	T	
C241	K3	C380	R10	C604	L8	J134	J3	L613	D9	R426	O8	T500	C7
C250	J6	C381	R8	C605	L9	J190	R5	L616	U5	R428	C10	T700	F6
C251	K5	C382	O7	C606	L9	J191	R5	L617	U5	R430	C10	T800	F5
C252	M8	C383	Q10	C607	L9	J192	R5	L618	U4	R437	P10	V	
C253	J7	C400	T9	C608	L9	J193	R3	L619	U4	R438	P10	V130	T8
C254	J8	C401	T10	C609	L9	J194	R5	L700	H4	R446	T7	V400	E10
C255	J8	C402	T8	C611	L4	J195	R3	L702	F7	R447	T6	V401	G10
C256	J7	C403	T8	C612	L3	J196	R5	L800	D3	R448	T7	V402	F10
C257	J8	C404	G10	C614	L3	J197	R5	L801	E4	R450	T8	V600	I11
C258	K8	C405	F10	C615	L4	J260	M6	L802	E6	R451	T7	V601	I10
C259	K9	C406	F9	C616	K3	J261	M6	L803	E6	R452	T7	V615	U3
C260	L8	C407	E9	C618	H6	J262	M6	L804	E6	R465	P10	V800	D4
C261	L9	C408	C4	C620	H6	J263	M6	L805	E6	R490	M6	X	
C262	L9	C409	D3	C623	D9	J264	M6	L807	E6	R491	R10	X131	I4
C263	K9	C410	D4	C625	D9	J265	M6	L807	E6	R492	R10	X132	V5
C264	K9	C411	S8	C626	D9	J313	Q11	N130	K3	R500	C5	X310	Q5
C265	K9	C420	H9	C627	J9	J314	Q11	N230	O4	R501	C7	X311	Q9
C266	J9	C422	G9	C629	T5	J315	Q11	N233	K3	R502	B7	X400	U6
C267	J8	C440	T6	C630	T5	J317	P11	N310	R11	R503	C7	X401	C4
C268	M7	C441	T6	C632	K9	J318	P11	N400	T9	R504	E8	X420	H8
C269	M7	C442	S6	C633	K9	J319	Q11	N500	E7	R505	F8	X602	K11
C270	M8	C443	S6	C634	K9	J370	O9	N607	K4	R506	F8	X603	K10
C271	M8	C444	T7	C635	K8	J371	O9	N700	F3	R511	D5	X604	L11
C272	J8	C445	T8	C636	U4	J373	O10	R	R512	D6	X605	L10	
C273	J8	C446	T7	C637	U4	J374	O10	R106	R4	R513	C8	X607	L11
C274	J6	C447	T7	C638	U4	J375	P10	R110	Q10	R514	F6	X812	C4
C275	J6	C460	Q7	C639	U4	J377	K3	R111	Q10	R515	D7	X813	C5
C276	J6	C461	Q5	C640	H5	J378	K4	R112	Q10	R516	E8	Z	
C277	L9	C462	S6	C641	G6	J380	P10	R113	Q10	R602	L8	Z191	T4
C278	J7	C463	R8	C702	F2	J460	S7	R114	Q10	R603	L8	Z192	T5
C279	J7	C464	S8	C703	F3	J461	Q7	R115	P10	R604	L8	Z400	U8
C280	J6	C465	S8	C704	F3	J462	S7	R130	J4	R605	L9	Z401	U4
C281	K5	C466	T10	C705	H3	J463	Q7	R131	J3	R606	L9	Z402	D10
C282	L8	C470	O7	C706	H4	J464	Q7	R133	M6	R607	L9	Z700	F7
C283	L8	C471	Q5	C707	G2	J465	T5	R134	J7	R608	K9	Z800	E3
C284	M8	C472	O5	C710	F4	J472	T9	R135	H5	R609	T7	Z801	D3
C285	M6	C490	M6	C711	G3	J473	R9	R136	U3	R610	T7	Z802	E5
C286	M6	C491	Q10	C712	G3	J474	T8	R137	U4	R611	L4	Z803	E5

